

**vtech**<sup>®</sup>  
Baby

# User's Manual

## Too-Too Drivers<sup>™</sup> Construction Site

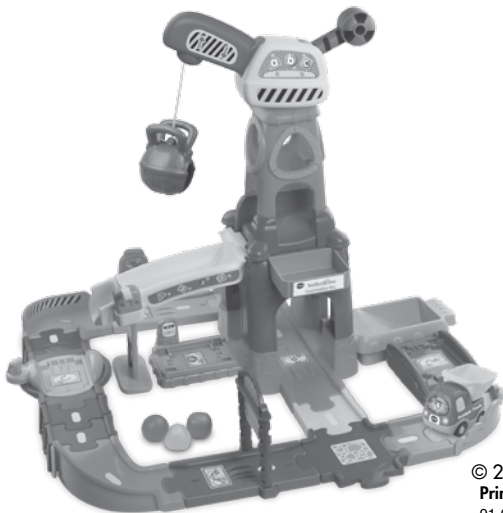

© 2013 VTech  
Printed in China  
91-002831-001 UK

**VTech understands that a child's needs and abilities change as they grow and with that in mind we develop our toys to teach and entertain at just the right level...**

## **vtech** Baby

**Toys that will stimulate their interest in different textures, sounds and colours**

### **I am...**

...responding to colours, sounds and textures

...understanding cause and effect

...learning to touch, reach, grasp, sit-up, crawl and toddle

**Birth-36 months**



## **Pre-School**

**Interactive toys to develop their imagination and encourage language development**

### **I want...**

...to get ready for school by starting to learn the alphabet and counting

...my learning to be as fun, easy and exciting as can be

...to show my creativity with drawing and music so my whole brain develops

**3-6 years**



## **Electronic Learning Computers**

**Cool, aspirational and inspiring computers for curriculum related learning**

### **I need...**

...challenging activities that can keep pace with my growing mind

...intelligent technology that adapts to my level of learning

...National Curriculum based content to support what I'm learning at school

**4-10 years**



To learn more about this and other VTech® products, visit [www.vtechuk.com](http://www.vtechuk.com)

# INTRODUCTION

Thank you for purchasing the **VTech® Toot-Toot Drivers® Construction Site** learning toy!

Let your little construction worker discover and explore with the **Toot-Toot Drivers® Construction Site** by **VTech®**! Pick up, sort and dump play pieces into the included dumper truck or down the crane tower with its cool rotating crane and working claw, building motor and role-play skills. Move around the site and dump the pieces into the cargo loader. The dumper truck or other **Toot-Toot Drivers®** vehicles (each sold separately. SmartPoint vehicles only.) can go into the weigh station and recognise six SmartPoint™ locations, encouraging first words and language skills. The whistle has blown and it's time to get to work. It's playtime with miles of learning!

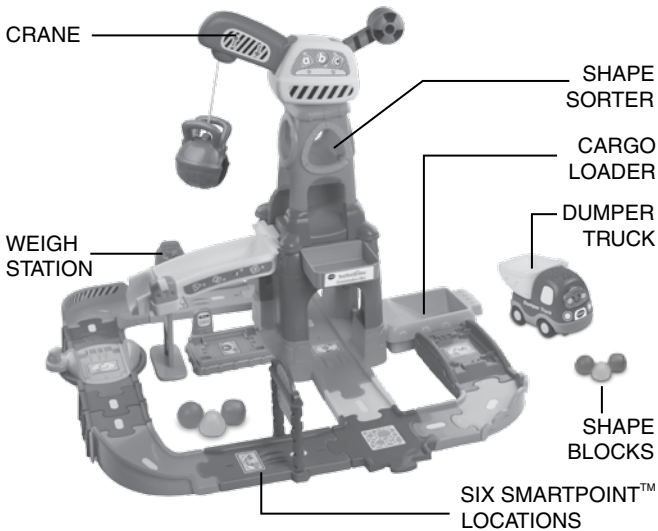

# INCLUDED IN THIS PACKAGE

- One user's manual

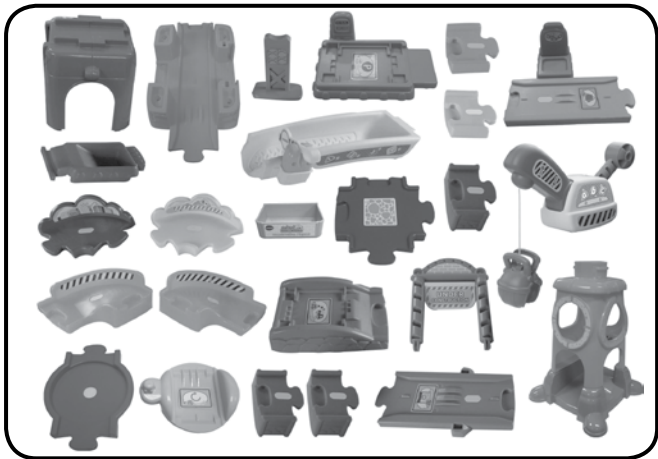

25 track and play pieces



One dumper truck

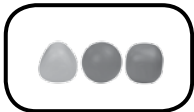

Three shape blocks



Four screws

**WARNING:** All packing materials, such as tape, plastic sheets, packaging locks and tags are not part of this toy, and should be discarded for your child's safety.

**NOTE:** Please keep this instruction manual as it contains important information.

# ASSEMBLY INSTRUCTIONS

With the **VTech® Toot-Toot Drivers® Construction Site**, safety comes first. To ensure your child's safety, adult assembly is required. This package contains four screws. For your child's safety, do not let your child play with the toy until it is fully assembled.

1. Attach the crane platform onto its orange SmartPoint™ base. Turn them over and use a screwdriver to tighten the four screws on the bottom.



2. Insert the cargo chute onto the crane platform by inserting the top end of it into the corresponding groove on the platform. You will hear it click into place. Then, add the support piece to the bottom of the chute.

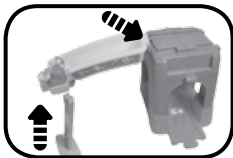

3. Insert the cargo loader onto the crane platform by tilting it and inserting the end of it into the corresponding groove. Insert the grey tray onto the crane platform by sliding the end of it into the corresponding groove on the platform.

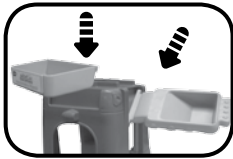

4. Insert the crane onto the crane tower. You will hear it click into place.



5. Insert the crane tower onto the platform.  
You will hear it click into place.



**Can be reconfigured for more ways to play!**

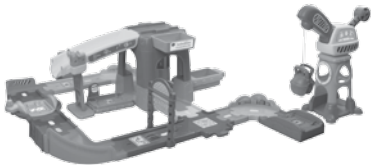
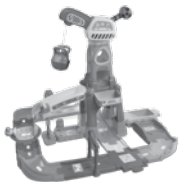

## GETTING STARTED

### BATTERY INSTALLATION

1. Make sure the unit is turned **OFF**.
2. Locate the battery cover on the bottom of the dumper truck. Use a coin or a screwdriver to loosen the screw.
3. Install 2 new AAA (AM-4/LR03) batteries following the diagram inside the battery box. (The use of new alkaline batteries is recommended for maximum performance.)
4. Replace the battery cover and tighten the screw to secure.

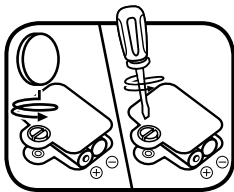

## BATTERY NOTICE

- Use new alkaline batteries for maximum performance.
- Use only batteries of the same or equivalent type as recommended.
- Do not mix different types of batteries: alkaline, standard (carbon-zinc) or rechargeable (Ni-Cd, Ni-MH), or new and used batteries.
- Do not use damaged batteries.
- Insert batteries with the correct polarity.
- Do not short-circuit the battery terminals.
- Remove exhausted batteries from the toy.
- Remove batteries during long periods of non-use.
- Do not dispose of batteries in fire.
- Do not charge non-rechargeable batteries.
- Remove rechargeable batteries from the toy before charging (if removable).
- Rechargeable batteries are only to be charged under adult supervision.

## Disposal of batteries and product



The crossed-out wheellie bin symbols on products and batteries, or on their respective packaging, indicates they must not be disposed of in domestic waste as they contain substances that can be damaging to the environment and human health.



The chemical symbols Hg, Cd or Pb, where marked, indicate that the battery contains more than the specified value of mercury (Hg), cadmium (Cd) or lead (Pb) set out in Battery Directive (2006/66/EC).

The solid bar indicates that the product was placed on the market after 13th August, 2005.

Help protect the environment by disposing of your product or batteries responsibly.

For more information, please visit:

[www.recycle-more.co.uk](http://www.recycle-more.co.uk)

[www.recyclenow.com](http://www.recyclenow.com)

# DUMPER TRUCK PRODUCT FEATURES

## 1. ON/OFF SWITCH

To turn the dumper truck **ON**, slide the **ON/OFF SWITCH** to the **ON** (⏻) position. To turn the dumper truck **OFF**, slide the **ON/OFF SWITCH** to the **OFF** (●) position.

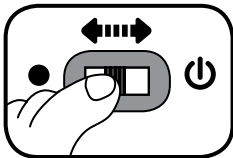

## 2. AUTOMATIC SHUT-OFF

To preserve battery life, the **VTech® Toot-Toot Drivers® Dumper Truck** will automatically power-down after approximately 30 seconds without input. The unit only can be turned on again by pressing the light-up button or pushing the dumper truck quickly.

# DUMPER TRUCK ACTIVITIES

1. Slide the **ON/OFF SWITCH** to turn the dump truck **ON**. You will hear dumper truck sounds, a song and a phrase. The light will flash with the sounds.

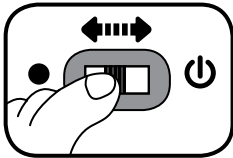

2. Press the **LIGHT-UP BUTTON** to hear dumper truck sounds, songs and phrases. The light will flash with sounds.



3. Push the dumper truck to hear fun sounds and melodies. While the melody is playing, push the dumper truck again to add in fun sounds on top of the melody. The light will flash with sounds.

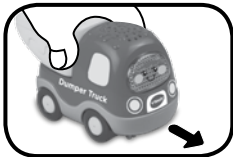



4. For added fun, the dumper truck interacts with the **Toot-Toot Drivers® Construction Site**. Simply roll the dumper truck over one of the construction site's six **SmartPoint™** locations to see the dump truck's light flash and to hear greetings, fun sounds, short tunes and sing-along songs. The dumper truck even interacts with other **Toot-Toot Drivers®** play sets (each playset sold separately).



If there is no input for approximately 8 seconds, you will hear a phrase and sound effects. After another 8 seconds of no input, a song will play. If there is no input for an additional 8 seconds, the dumper truck will play a short tune and then go into sleep mode. The dumper truck can be re-activated by pressing the light-up button or pushing the dumper truck quickly.

## MELODY LIST

1. Humpty Dumpty
2. Skip to My Lou
3. Pop! Goes the Weasel
4. Little Boy Blue
5. Hickory Dickory Dock
6. This Old Man

## SING-ALONG SONG LYRICS

### SONG 1

I'm a useful dumper truck,  
helping the builders,  
at the construction site,  
working hard till sunset.

## **SONG 2**

Load some rocks, 1,2,3.

Day and night,now time to stop!

## **SONG 3**

Tip my bed, up and down.

Load and unload, all around!

# **CARE & MAINTENANCE**

1. Keep the unit clean by wiping it with a slightly damp cloth.
2. Keep the unit out of direct sunlight and away from any direct heat source.
3. Remove the batteries when the unit will not be in use for an extended period of time.
4. Do not drop the unit on hard surfaces and do not expose the unit to moisture or water.

# **TROUBLESHOOTING**

If for some reason the program/activity stops working or malfunctions, please follow these steps:

1. Please turn the unit OFF.
2. Interrupt the power supply by removing the batteries.
3. Let the unit stand for a few minutes, then replace the batteries.
4. Turn the unit ON. The unit should now be ready to play again.
5. If the product still does not work, replace with an entire set of new batteries.

If the problem persists, please call our Consumer Services Department on 01235 546810 (from UK) or +44 1235 546810 (outside UK) and a service representative will be happy to help you.

**IMPORTANT NOTE:**

Creating and developing **VTech®** products is accompanied by a responsibility that we take very seriously. We make every effort to ensure the accuracy of the information, which forms the value of our products. However, errors sometimes can occur. It is important for you to know that we stand behind our products and encourage you to call our Consumer Services Department on 01235 546810 (from UK) or +44 1235 546810 (outside UK), with any problems and/or suggestions that you might have. A service representative will be happy to help you.



**CLASS 1  
LED PRODUCT**



## PRODUCT WARRANTY



Thank you for choosing this quality product from VTech. We hope it will bring many hours of entertainment, imaginative play and learning.

1. The product detailed above is covered by a one year warranty from the date of purchase, against any defects in materials or workmanship.
2. The product may be returned to the place of purchase. Alternatively the product can be returned to VTech Electronics Europe plc (see address below), with proof of purchase, without proof of purchase no replacement will be provided.
3. VTech Electronics Europe plc will examine the product and if it is found to be defective due to faulty materials or workmanship, will replace the product at their discretion.
4. If the product covered by this warranty is damaged due to misuse, modification or unauthorised repair, or because of faulty batteries, battery discharge or incorrect electrical connections, then this warranty becomes void.
5. This warranty is personal to the original purchaser and is not transferable.
6. Breakages to the LCD screen are not covered by the warranty.
7. Returns to VTech Electronics Europe plc should include a cheque or postal order for £1.50 towards the cost of return postage and packaging.
8. Products returned to VTech Electronics Europe plc, should be addressed as follows and packed carefully to avoid damage in transit (Please do not include batteries or adaptor).  
Please include details of the fault together with your name and address.

VTech Electronics Europe plc, c/o Tablogix Limited, 200 Milton Park, Abingdon, Oxon OX14 4TA

**THIS WARRANTY IS OFFERED AS AN EXTRA BENEFIT AND DOES NOT AFFECT CONSUMERS' STATUTORY RIGHTS.**

This warranty is valid for the UK and Eire only. For products purchased outside the UK and Eire, please contact your local distributor or place of purchase.

